

Archive document from G1MFG.com

The best ATV gear in the world...

13cm LCD controller technical information – V3 software

This document is provided as-is, without any warranty.

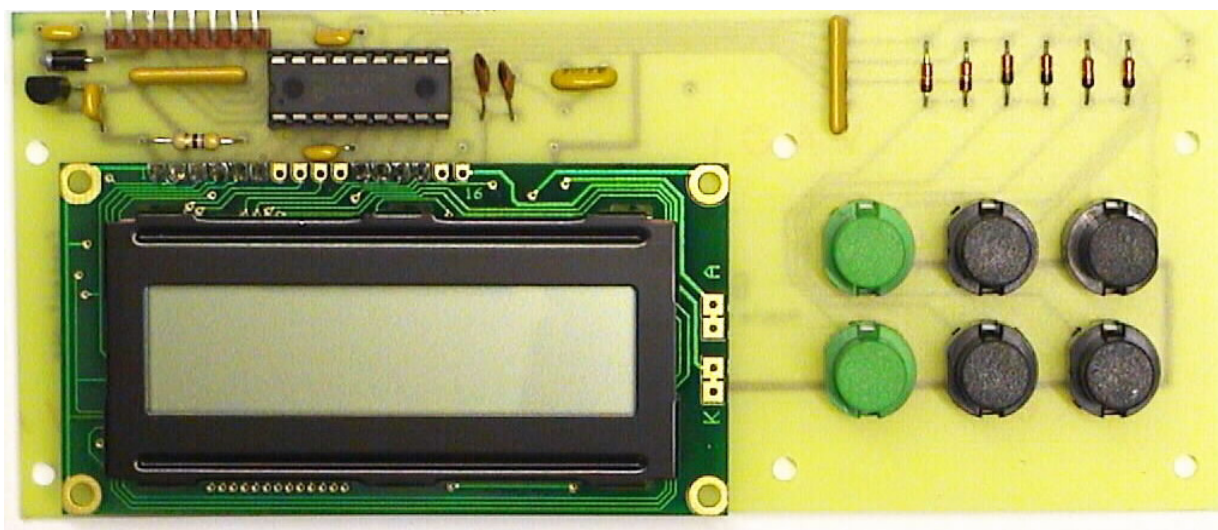

The 13cm LCD transceiver controller

Specification

The G1MFG.com 13cm LCD controller provides our transmitters and receivers with the following features:

	Receiver	Transmitter
Frequency range	2.200GHz - 2.700GHz	2.310GHz - 2.450GHz
Frequency steps	125kHz	125kHz
Number of VFOs	3	3
Automatic net to Tx frequency	Yes, selectable	N/A
Power supply requirement: 12V DC nominal (10-18V), 10mA (standard), 50mA (backlit)		

Principles of operation

The LCD controller contains a PIC microprocessor which provides control signals direct to the synthesisers within the transmitter and receiver modules, replacing the 18 pin PICs on the transmitter and receiver printed circuit boards. The controller is compatible with G1MFG 13cm transmitter and the standard 15 channel or "ENG" receivers. Both receivers give identical features when used with the LCD controller. The controller will work fine with a receiver or a receiver and transmitter, but will not operate with a standalone transmitter. Please be aware that although the controller will instruct the receiver to operate between 2.2-2.7GHz, we cannot absolutely guarantee that all receivers will be capable of operating at the extreme frequency edges.

Frequency selection is now achieved by up/down tuning buttons, and the transmit and receive frequencies are displayed on the LCD display. The transmitter and receiver frequencies are controlled independently. Three VFOs are provided for the transmitter and three for the receiver.

The controller includes a Band Scan mode which sweeps the receiver across its whole tuning range. The scan can be stopped at any time by pressing any key or by toggling the 'Net' input to ground.

Installation

Switch off the transmitter.

Switch off the receiver.

Remove the 18 pin PIC chip (if fitted) from its socket on the transmitter PCB.

Remove the 18 pin PIC chip (if fitted) from its socket on the receiver PCB.

The PICs are no longer required and may be used for your own experiments or returned to G1MFG.com.

Identifying the connections

This is the pinout of the LCD controller. Note that not all versions have the pin header fitted.

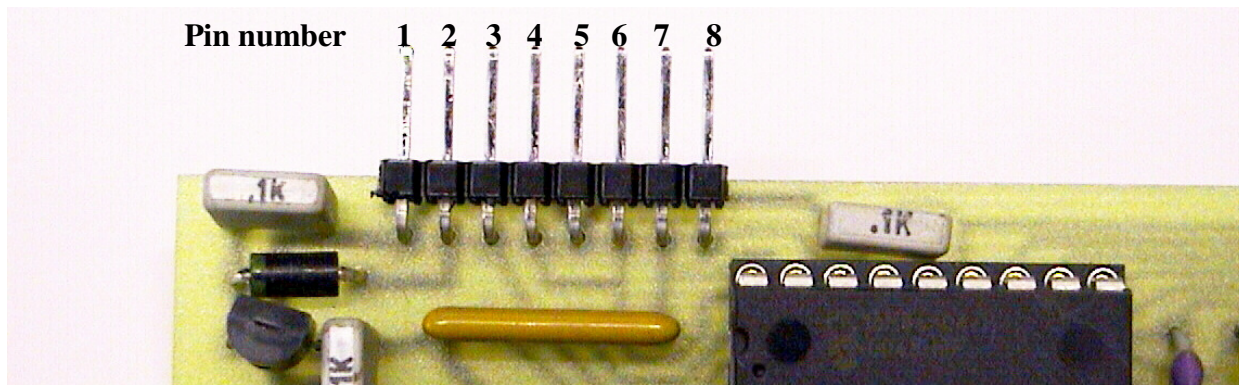

Identifying the controller pins

The pin assignments are as follows:

Controller pin	Function
1	0V (ground) from power supply – must also connect to Tx and Rx 0V line
2	+12V from power supply
3	SDA (serial data) to receiver module
4	SCL (serial clock) to receiver module
5	0V (ground) to transmitter (optional connection if pin 1 is connected to Tx)
6	SCL (serial clock) to transmitter module
7	SDA (serial data) to transmitter module
8	NET input (ground to activate)

Transmitter and receiver connections

Identify the SCL and SDA pins on the transmitter module. The SDA pin is the bottom one, and SCL is the next one up.

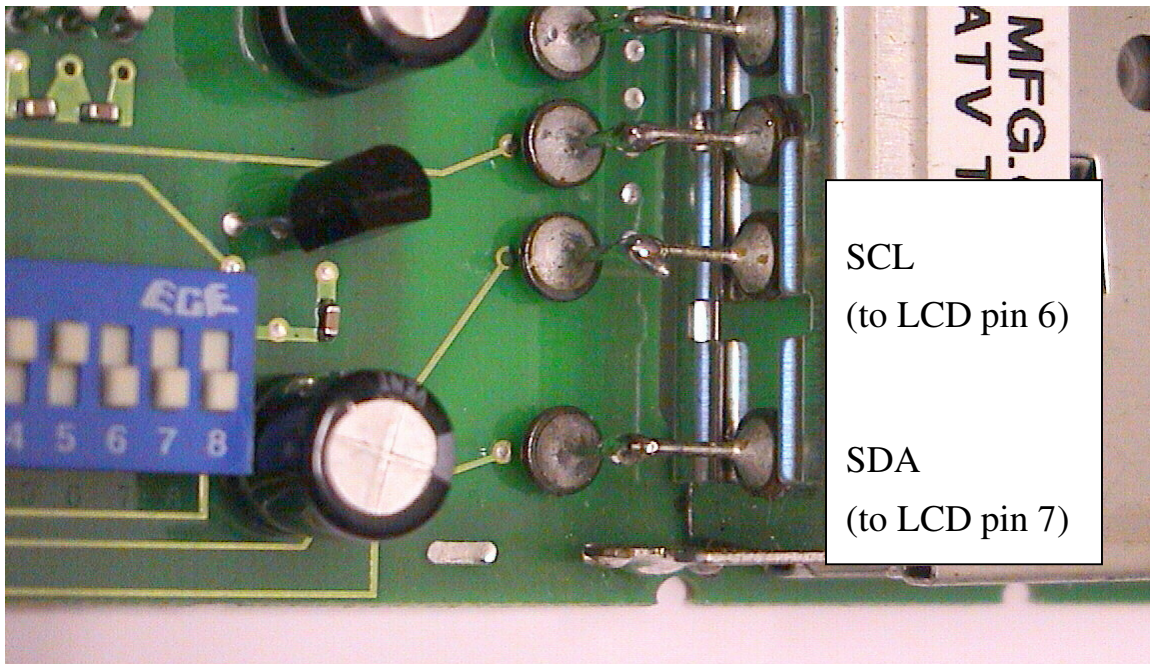

Transmitter pin identification

Identify the SCL and SDA pins on the receiver module. The SCL pin is the bottom one, and the SDA pin is the next one up. *Note that this is the opposite way round to the transmitter.*

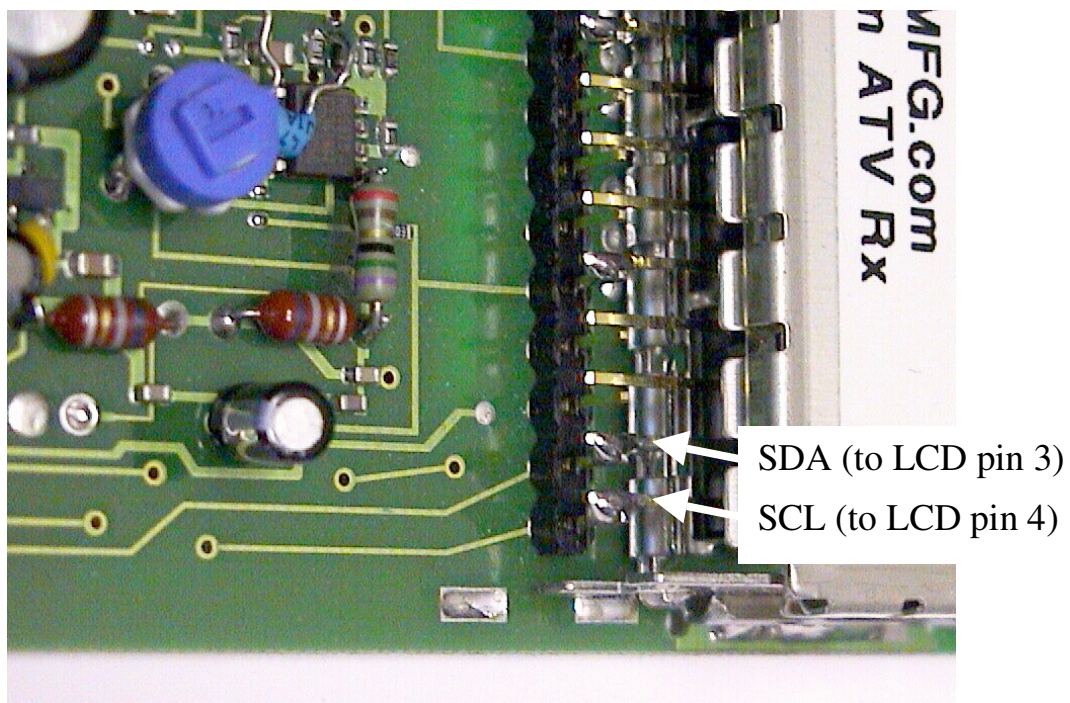

Receiver pin identification

(the above picture shows the 23cm receiver but the pins are the same).

Wiring diagram

Wire up the LCD controller, transmitter and receiver as shown in the following diagram.

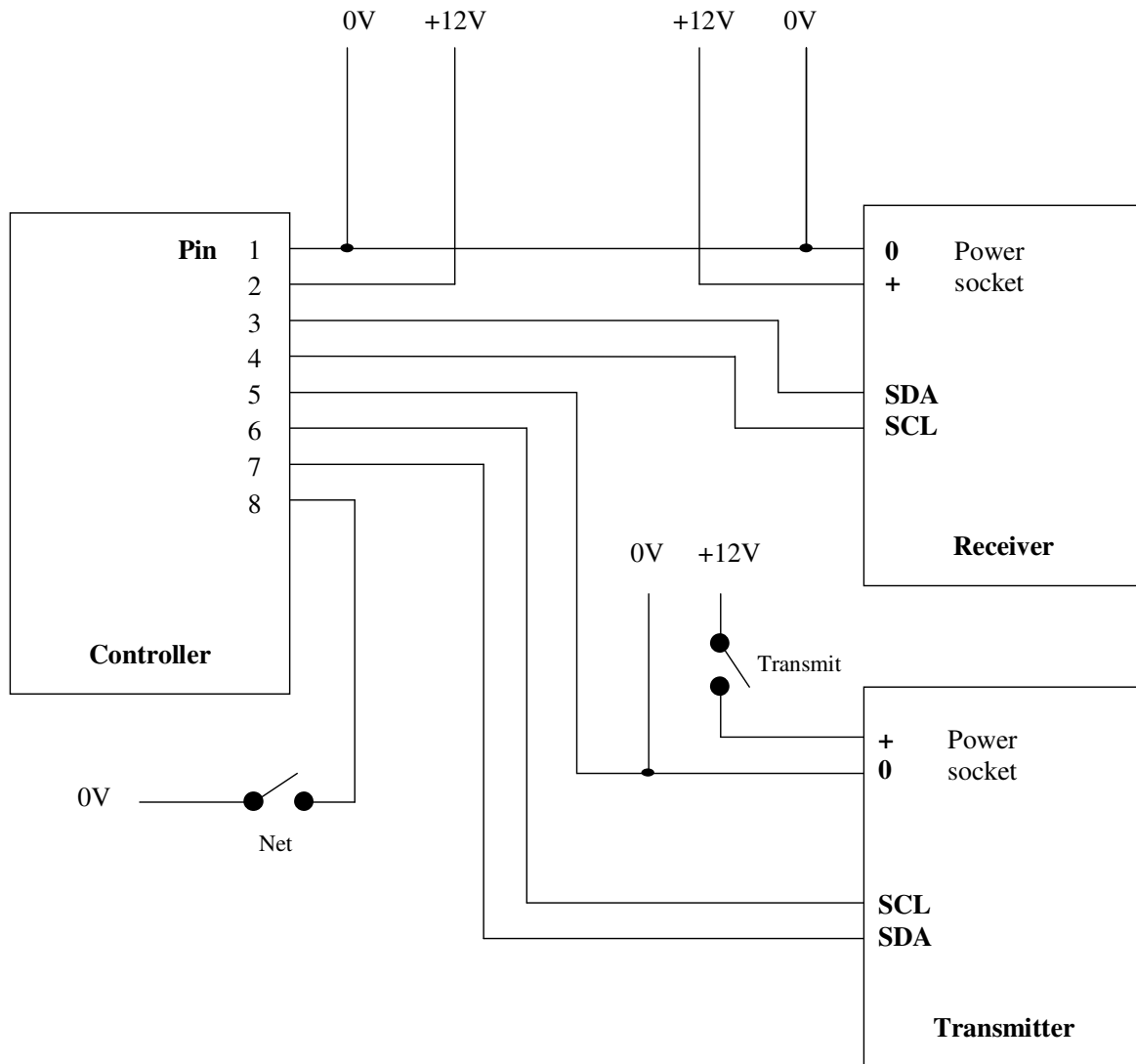

Wiring diagram

The Net switch is optional. It can be used to net the receiver to the transmitter frequency for use with repeaters, and it also provides a 'scan stop' control.

The controller is designed to be used fairly close to the transmitter and receiver modules. We recommend that the connections between the controller, transmitter and receiver are no more than about 1m (40") maximum. The actual maximum for reliable operation depends on the capacitance of the cable. The capacitance to ground and to each other of the SCL and SDA wires should not exceed about 200-300pF. You may be able to get away with longer interconnections by using low-capacitance cabling but we cannot guarantee success. If you need significantly longer connections, you can use Philips I²C Bus Extender ICs, P82B715, to drive the lines. You will need four ICs – two at the controller end and two at the transmitter/receiver end. We have heard reports of people running up to 30m of control cable using these ICs, which are available from Farnell and other suppliers. At the time of writing (April 2001) the ICs cost about £5.

Note that the controller uses software to detect when the transmitter is switched on, which is why there isn't a connection between the Transmit switch and the controller board.

Important notes about your receiver and/or transmitter

Power supply

The transmitter and receiver require a supply of supply of 12 to 15V DC, tip positive. Reverse polarity will cause very serious damage. The transmitter gives best output power at 13.8V or more. Do NOT use less than 12V for either the transmitter or the receiver.

If your receiver has two voltage regulators mounted on heatsinks then we recommend operating it from 12V. Supplies above 14V will make the regulators run very hot.

Video and audio connections

Video and audio connections (inputs on the Tx and outputs on the Rx) are as follows:

- Yellow phono socket - composite video
- White phono socket - audio for/from 6.0MHz subcarrier
- Red phono socket - audio for/from 6.5MHz subcarrier

Video deviation

Transmitter deviation and receiver video gain (contrast) are set using the pre-set pot on the PCB.

As supplied, the transmitter input impedance is about 1Kohm. You may want to fit a 75 or 82 ohm resistor across the video input socket to provide a better match to 75 ohm video systems.

Pre-emphasis/de-emphasis

The transmitter and receiver do not include video pre- or de-emphasis, but this can be done using information on our web site at www.G1MFG.com/pcb/

Operating instructions

When you switch on the controller, a sign-on display will appear briefly, which will then be replaced by a display of the transmit and receive frequencies.

R	x	2	3	4	5	.	0	0	0	M	H	z	
_	T	x	2	3	4	5	.	0	0	0	M	H	z

Normal operating display

Use the buttons to change frequency. Separate buttons are provided for the transmitter and receiver.

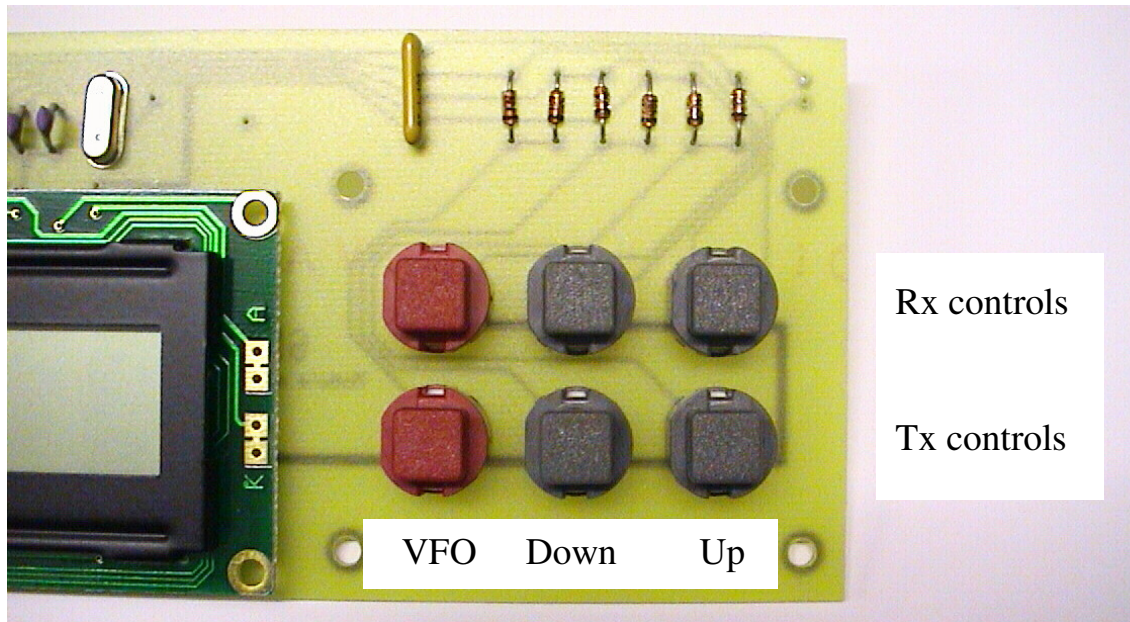

Identifying the pushbuttons

The Up and Down buttons increase and decrease the frequency. The VFO button swaps between the three VFOs. Frequency changes are immediately sent to the receiver and transmitter. The tuning rate is initially quite slow, and it speeds up if you keep a button pressed.

The controller stores the Tx and Rx frequencies in internal memory after a short delay. An underscore (_) is shown on the display beside "Tx" while the controller is waiting to store the frequencies.

- The reason for this delay is that the memory only survives a few million write cycles and is relatively slow. If the memory was written every time the frequency gets changed, it would reduce the maximum scan speed and the memory would be destroyed after a few weeks of continuous scanning.
- **Do NOT switch the controller off while the underscore (_) is showing or the controller may be damaged.**

AutoNet option

If you connect the AutoNet pin (8) to 0V, then the controller will automatically re-tune the receiver to the transmit frequency whenever the transmitter is switched on. This is useful when working via a repeater, because you will be able to see your transmitted signal. As soon as you switch the transmitter off, the receiver re-tunes to its original frequency. Please note that the Net pin is also used with the Band Scan function described below.

Band Scan

The 13cm receiver controller includes a band scan mode, which sweeps the receiver across the whole receive frequency range (2200-2700 MHz).

To activate Band Scan, press the two VFO Swap controls simultaneously. The display will change to the Band Scan display:

R	x		2	2	0	0	.	0	0	0		M	H	z
---	---	--	---	---	---	---	---	---	---	---	--	---	---	---

Scan mode

The receiver will sweep the whole Rx frequency range in 500kHz steps. It will keep scanning indefinitely, or until you stop it by:

- Pressing any pushbutton
- Connecting the Net input to 0V.

Note that the Net/Scan Stop input must NEVER be connected to any positive supply. It must be left floating or grounded. It is pulled to +5V by a resistor on the controller PCB.

When the scan is stopped, the receiver is tuned to the scan frequency and the transmitter remains at whatever frequency was selected before you started scanning.

We do not recommend switching the transmitter on while scanning. If you do switch the transmitter on, it will operate on whatever frequency the current Tx VFO is set to but the display will not show the Tx frequency.

Addendum: using the LCD controller with other transmitters and receivers

The following information is intended for the experienced constructor only.

There are a number of other video transmitters and receivers available for the 2.4GHz band, usually sold as "Videosenders" or wireless security cameras. Many of these are compatible with the G1MFG.com 13cm LCD controller.

Many of these devices use the same SP5055 synthesiser IC as is used in the G1MFG gear, or a very similar IC. Usually there is a microcontroller - like a PIC - which provides frequency control information to the synthesiser via a two-wire I2C bus. In the case of the SP5055 the SDA line is on pin 4 and SCL is pin 5. If you break these two connections between the synthesiser and microcontroller and connect the appropriate (Tx or Rx) SCL and SDA lines as shown the wiring diagram on page 4 of this manual (and make sure there is a common ground return) you will probably find that the LCD controller will work fine. Please note that this information is intended for experienced persons only - we will not be held liable for damage caused to your equipment!